

## Piezoelectric Ceramic Buzzer (SMD Type)

<b>2-4</b>	HPS16C
<b>5-7</b>	PKMCS0909E4000-R1
<b>8-10</b>	HPS12F
<b>11-13</b>	KSE-SMT-14*04
<b>14-16</b>	HPS13C

**1. Product type: Piezoelectric Ceramic Buzzer (SMD Type)**
**2. Technical Parameter Measuring condition**

Part shall be measured under a condition (Temperature: 5 ~ 35°C, Humidity: 45% ~ 85%R.H., Atmospheric pressure: 860 ~ 1060hPa) unless the standard condition (Temperature: 25±3°C, Humidity: 60±10%R.H. Atmospheric pressure: 860 ~ 1060hPa) is regulated to measure.



1	Resonant Frequency	4000 ± 500Hz
2	Operating Voltage	1 ~ 25 Vp-p
3	Rated Current	Max.3mA , At 4KHz 50% duty Square Wave 3Vp-p
4	Sound Output at 10cm	Min. 75dB, At 4KHz 50% duty Square Wave 3Vp-p
5	Capacitance	14000 ± 30% pF At 1KHz
6	Operating Temperature	-30°C ~ +70°C
7	Store Temperature	-40°C ~ +85°C
8	Net Weight	Approx 1g
9	RoHS	Yes

**3. Dimensions**

Unit: mm

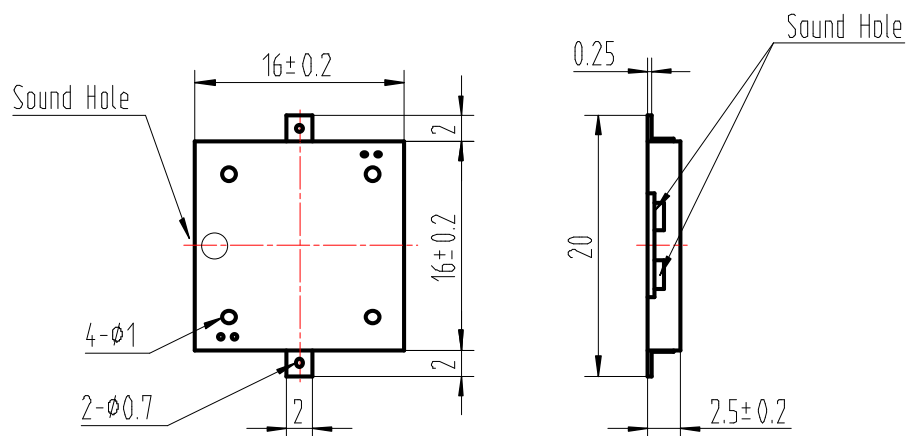

\*Unit: mm; Tolerance: ± 0.5mm Except Specified

\*Housing Material: LCP

**4. Electrical And Acoustical Measuring Condition**

**Recommended Setting**

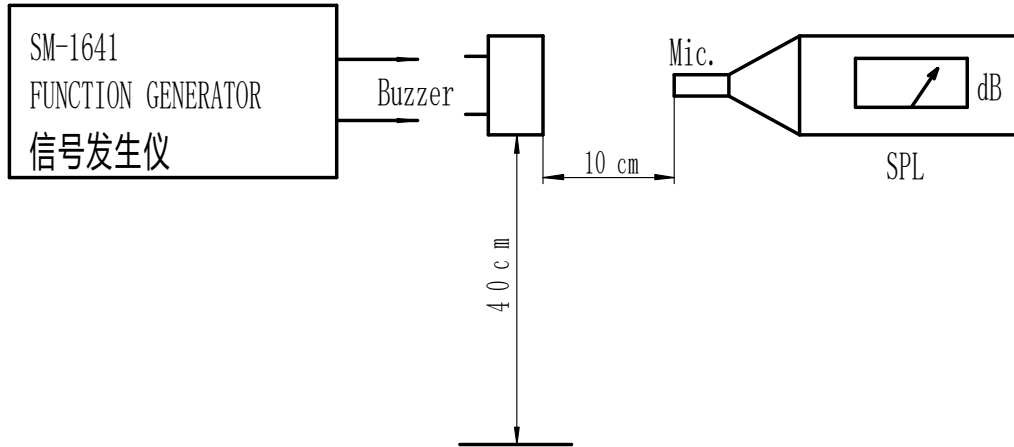

**5. Frequency Response**

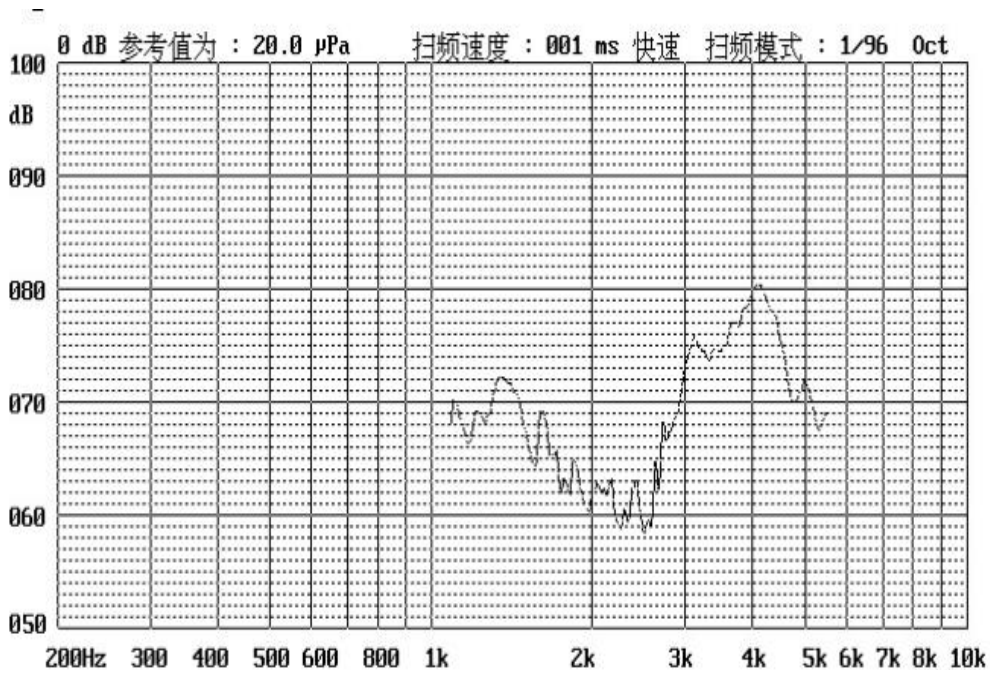

3Vp-p 50% duty Square wave, 10cm

**6.Surface mounting condition**

**6.1 Reflow soldering**

Recommendable reflow soldering condition is as follows.

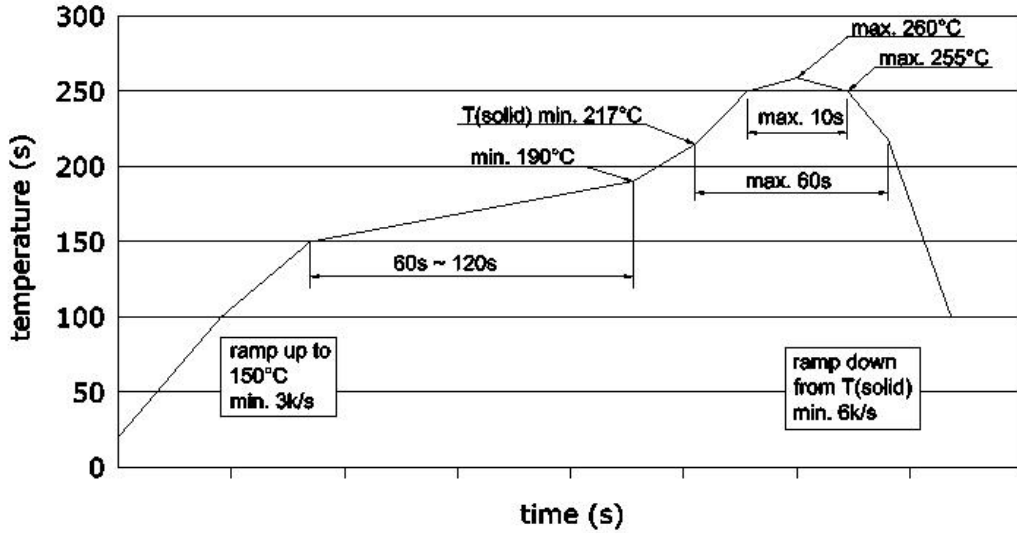

**4 Recommended reflow oven temperature profile**

- Note:** (1) In automated mounting of the SMD sound transducers on PCB, any bending, expanding and pulling forces or shocks against the SMD sound transducers shall be kept minimum to prevent them from electrical failures and mechanical damages of the devices.  
 (2) In the reflow soldering, too high soldering temperatures and too large temperature Gradient such as rapid heating or cooling may cause electrical failures and mechanical damages of the devices.

**6.2 Soldering pattern**

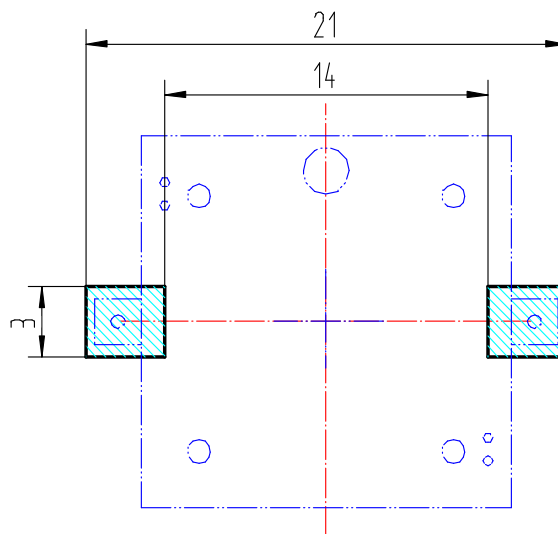

Piezoelectric Ceramic Buzzer

1. Product type: Piezoelectric Ceramic Buzzer (SMD Type)

2. Technical Parameter

Measuring condition

Part shall be measured under a condition (Temperature: 5 ~ 35°C, Humidity: 45% ~ 85%R.H., Atmospheric pressure: 860 ~ 1060hPa) unless the standard condition (Temperature: 25±3 °C, Humidity: 60±10%R.H. Atmospheric pressure: 860 ~ 1060hPa) is regulated to measure.



1	Resonant Frequency	4000Hz
2	Operating Voltage	1 ~ 20 Vp-p
3	Rated Current	Max.2mA ,at 4KHz 50% duty Square Wave 3Vp-p
4	Sound Output at 10cm	Min. 65dB,at 4KHz 50% duty Square Wave 3Vp-p
5	Capacitance	13000 ± 30%pF at 1KHz
6	Operating Temperature	-40°C ~ +85°C
7	Store Temperature	-40°C ~ +85°C
8	Net Weight	Approx 0.2g
9	RoHS	Yes

3. Dimensions

Unit: mm

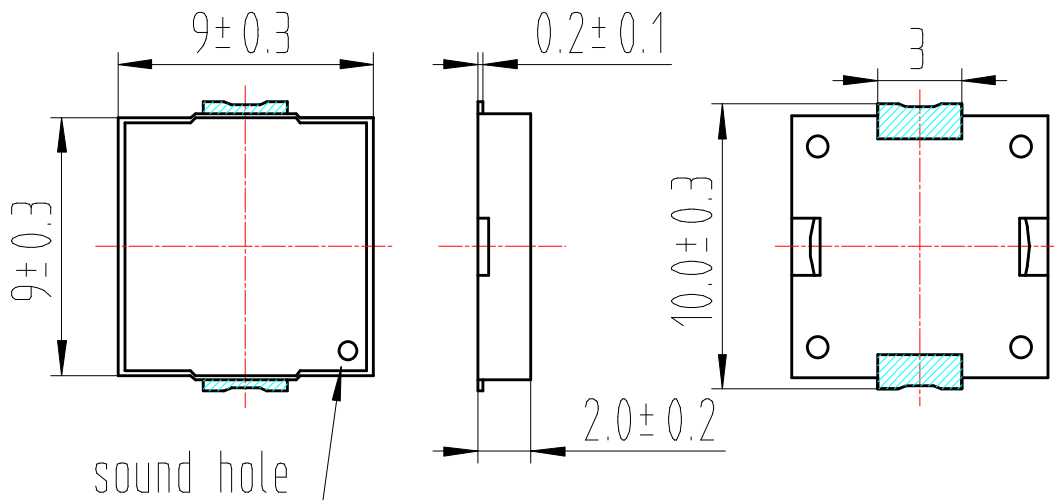

\*Unit: mm; Tolerance: ±0.3mm Except Specified

\*Housing Material: Black LCP

\*Terminal plate: 2 soldering pads, Sn Plating Brass

#### 4. Electrical And Acoustical Measuring Condition

##### Recommended Setting

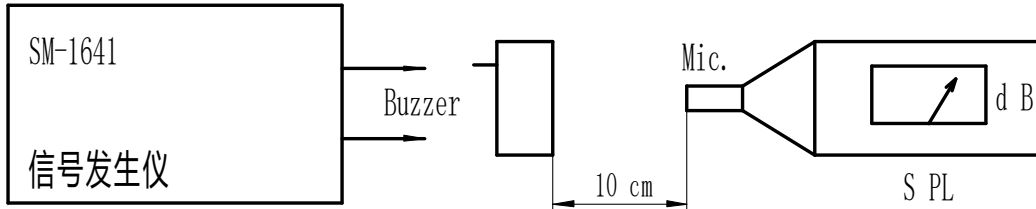

#### 5. Frequency Response



3Vp-p 50% duty Square wave, 10cm

**6. Surface mounting condition**

**6.1 Reflow soldering**

Recommendable reflow soldering condition is as follows.

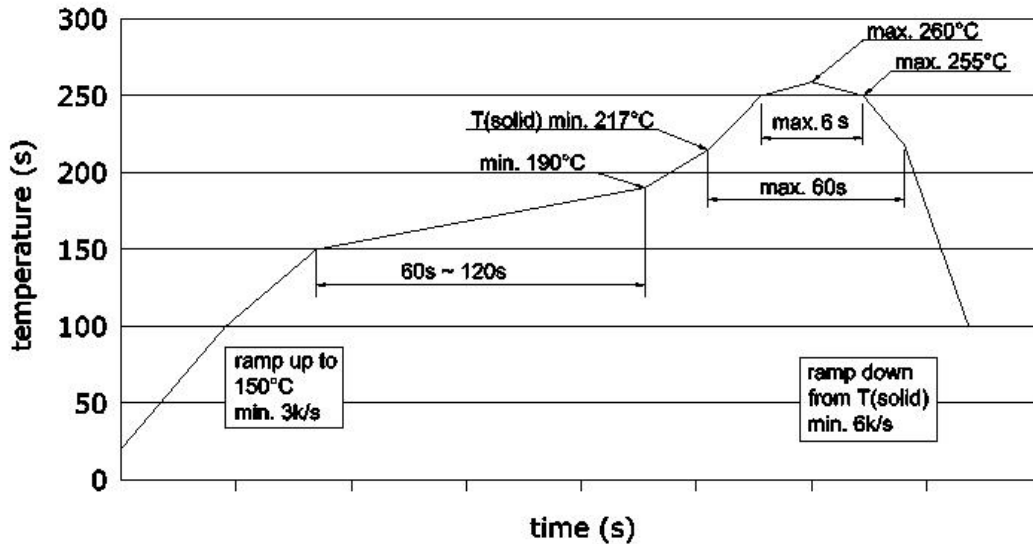

**Recommended reflow oven temperature profile**

- Note:** (1) In automated mounting of the SMD sound transducers on PCB, any bending, expanding and pulling forces or shocks against the SMD sound transducers shall be kept minimum to prevent them from electrical failures and mechanical damages of the devices.
- (2) In the reflow soldering, too high soldering temperatures and too large temperature Gradient such as rapid heating or cooling may cause electrical failures and mechanical damages of the devices.

**6.2 Soldering pattern**

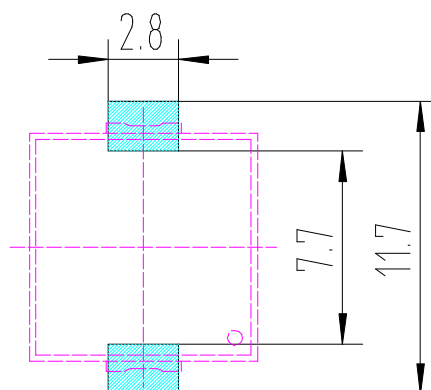

**1. Product type: Piezoelectric Ceramic Buzzer (SMD Type)**
**2. Technical Parameter**

Measuring condition

Part shall be measured under a condition (Temperature: 5 ~ 35°C, Humidity: 45% ~ 85%R.H. Atmospheric pressure: 860~1060hPa) unless the standard condition (Temperature: 25±3°C, Humidity: 60±10%R.H. Atmospheric pressure: 860 ~ 1060hPa) is regulated to measure.

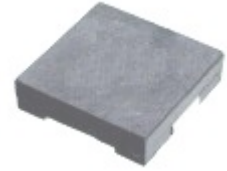

1	Resonant Frequency	4000Hz
2	Operating Voltage	1 ~ 25 Vp-p
3	Rated Current	Max.5mA ,at 4KHz 50% duty Square Wave 5Vp-p
4	Sound Output at 10cm	Min. 80dB,at 4KHz 50% duty Square Wave 5Vp-p
5	Capacitance	16000±30%pF at 120Hz
6	Operating Temperature	-30°C ~ +70°C
7	Store Temperature	-40°C ~ +85°C
8	Net Weight	Approx 0.5g
9	RoHS	Yes

**3. Dimensions**

Unit: mm

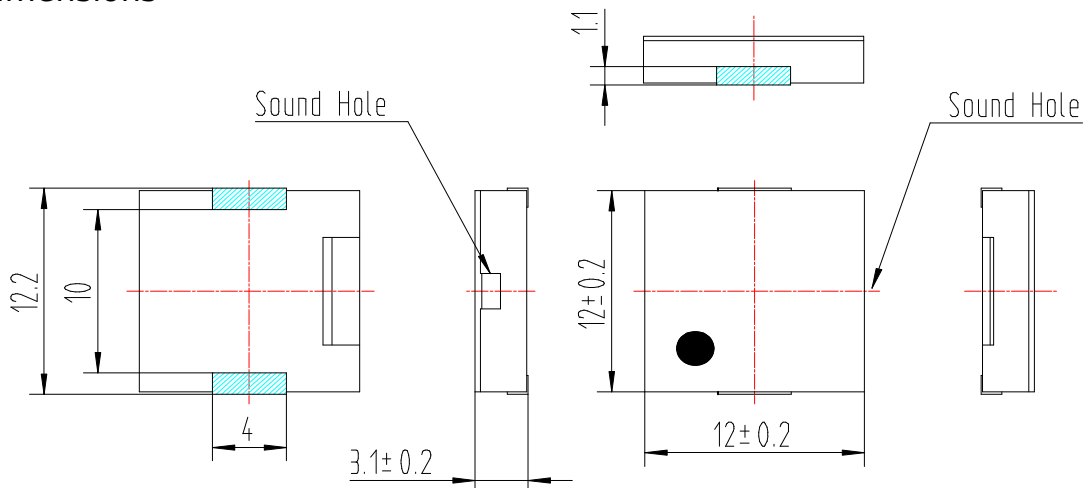

\*Unit: mm; Tolerance: ±0.3mm Except Specified

\*Housing Material: Black LCP

\*Terminal plate: 2 soldering pads, tin Plating Brass

4. Electrical And Acoustical Measuring Condition

Recommended Setting

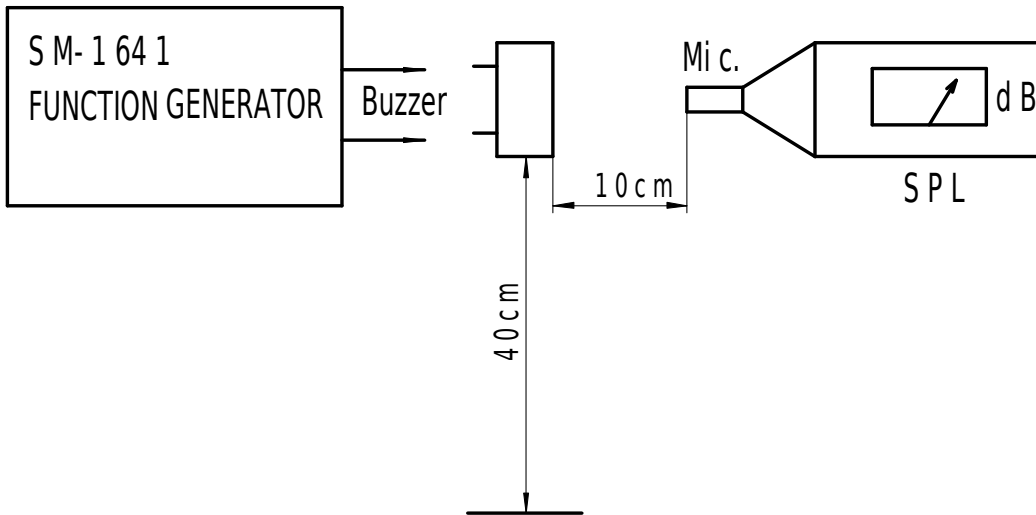

5. Frequency Response

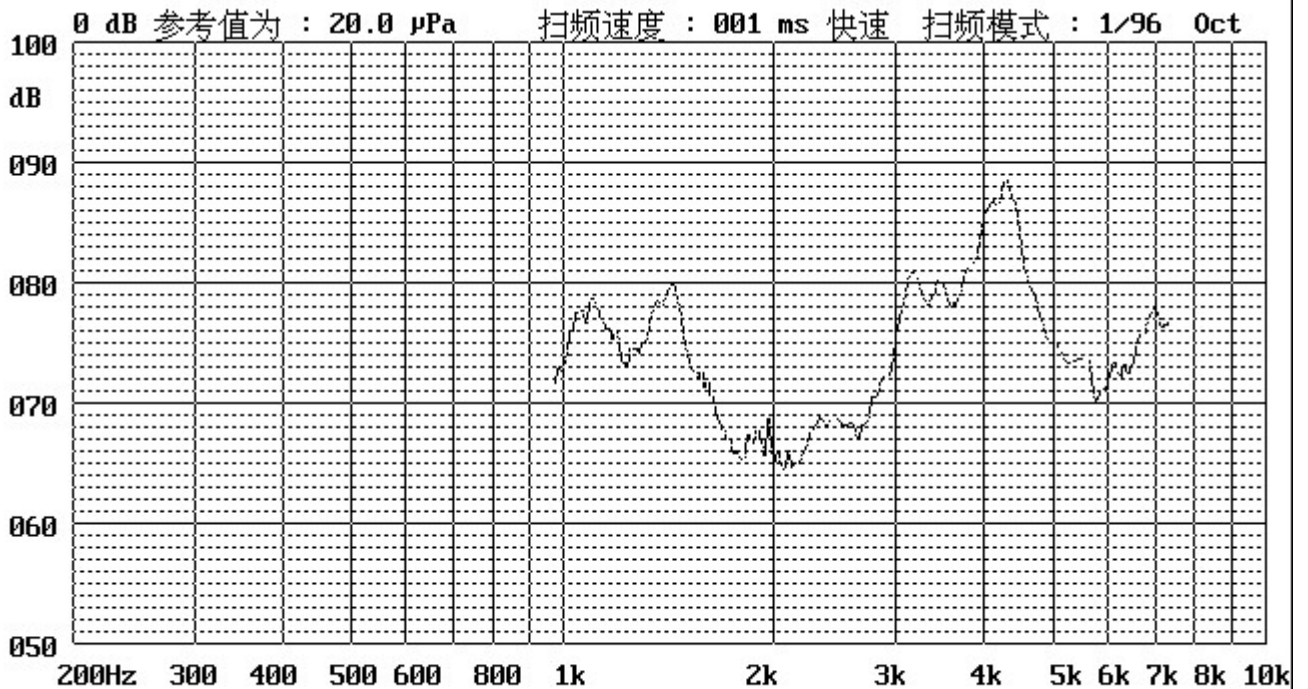

5Vp-p 50% duty Square wave, 10cm

**Piezoelectric Ceramic Buzzer**

6. Surface mounting condition

6.1 Reflow soldering

Recommendable reflow soldering condition is as follows.

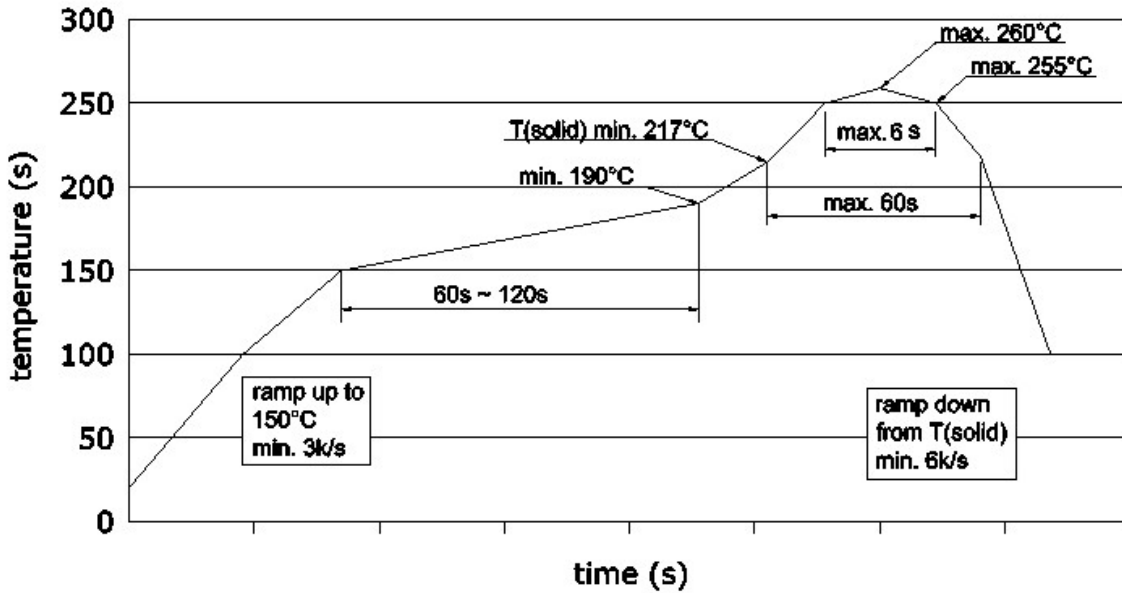

**Recommended reflow oven temperature profile**

Note: (1) In automated mounting of the SMD sound transducers on PCB, any bending, expanding and pulling forces or shocks against the SMD sound transducers shall be kept minimum to prevent them from electrical failures and mechanical damages of the devices.

(2) In the reflow soldering, too high soldering temperatures and too large temperature Gradient such as rapid heating or cooling may cause electrical failures and mechanical damages of the devices.

6.2 Soldering pattern

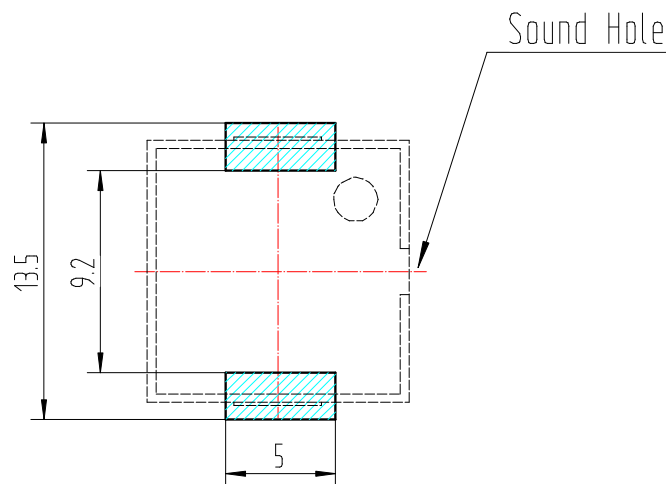

**1. Product type: Piezoelectric Ceramic Buzzer (SMD Type)**
**2. Technical Parameter**
**Measuring condition**

Part shall be measured under a condition (Temperature: 5 ~ 35°C, Humidity: 45% ~ 85%R.H.,

Atmospheric pressure: 860 ~ 1060hPa) unless the standard condition (Temperature: 25±3°C,

Humidity: 60±10%R.H. Atmospheric pressure: 860 ~ 1060hPa) is regulated to measure.



1	Resonant Frequency	4000Hz
2	Operating Voltage	1 ~ 20 Vp-p
3	Rated Current	Max.3mA ,at 4KHz 50% duty Square Wave 5Vp-p
4	Sound Output at 10cm	Min. 85dB,at 4KHz 50% duty Square Wave 5Vp-p
5	Capacitance	15000 ± 30%pF at 1KHz
6	Operating Temperature	-30°C ~ 70°C
7	Store Temperature	-40°C ~ 85°C
8	Net Weight	Approx 0.7g
9	RoHS	Yes

**3. Dimensions**

Unit: mm

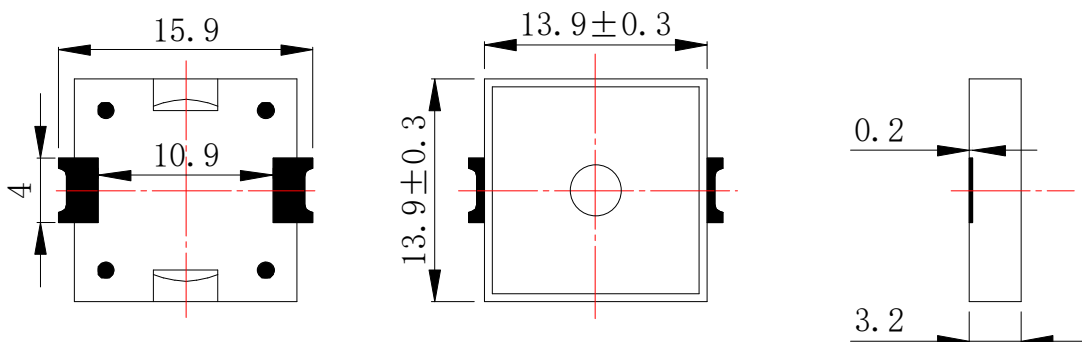

\*Unit: mm; Tolerance: ±0.3mm Except Specified

\*Housing Material: Black PPS

#### 4. Electrical And Acoustical Measuring Condition

##### Recommended Setting

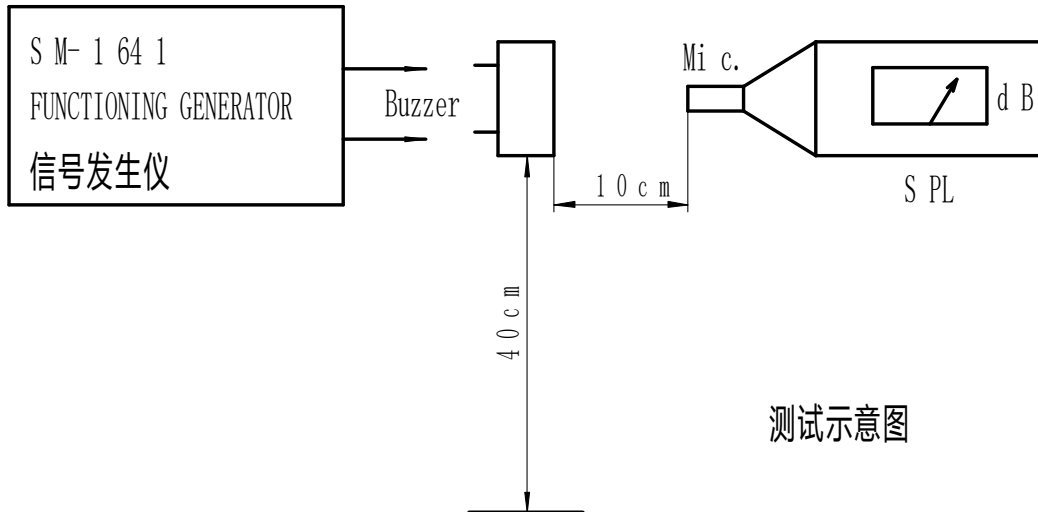

#### 5. Frequency Response



5Vp-p 50% duty Square wave, 10cm

## 6. Surface mounting condition

### 6.1 Reflow soldering

Recommendable reflow soldering condition is as follows.

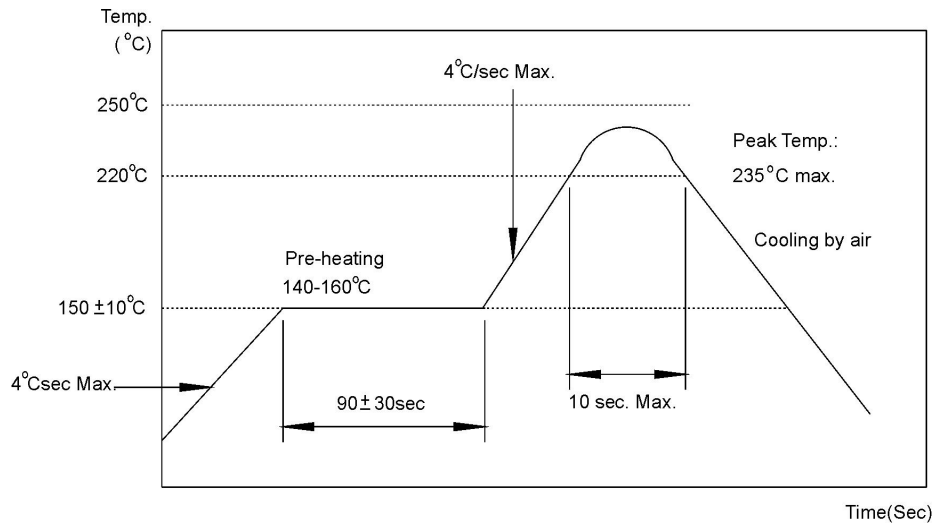

- Note:** (1) In automated mounting of the SMD sound transducers on PCB, any bending, expanding and pulling forces or shocks against the SMD sound transducers shall be kept minimum to prevent them from electrical failures and mechanical damages of the devices.
- (2) In the reflow soldering, too high soldering temperatures and too large temperature Gradient such as rapid heating or cooling may cause electrical failures and mechanical damages of the devices.

### 6.2 Soldering pattern

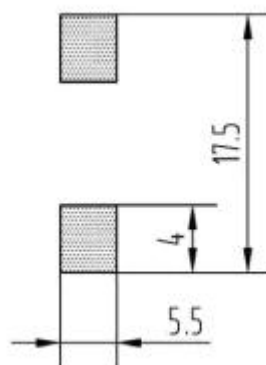

**Piezoelectric Ceramic Buzzer**
**1. Product type: Piezoelectric Ceramic Buzzer (SMD Type)**
**2. Technical Parameter**

Part shall be measured under a condition (Temperature: 5 ~ 35°C, Humidity: 45% ~ 85%R.H., Atmospheric pressure: 860 ~ 1060hPa) unless the standard condition (Temperature: 25±3°C, Humidity: 60±10%R.H. Atmospheric pressure: 860 ~ 1060hPa) is regulated to measure.



1	Resonant Frequency	4100 ± 500Hz
2	Operating Voltage	1 ~ 20 Vp-p
3	Rated Current	Max. 1mA ,at 4.1KHz 50% duty Square Wave 5Vp-p
4	Sound Output at 10cm	Min. 75dB,at 4.1KHz 50% duty Square Wave 5Vp-p
5	Capacitance	15000 ± 30%pF at 1KHz
6	Operating Temperature	-20°C ~ 70°C
7	Store Temperature	-30°C ~ 80°C
8	Net Weight	Approx 0.5g
9	RoHS	Yes

**3. Dimensions**

Unit: mm

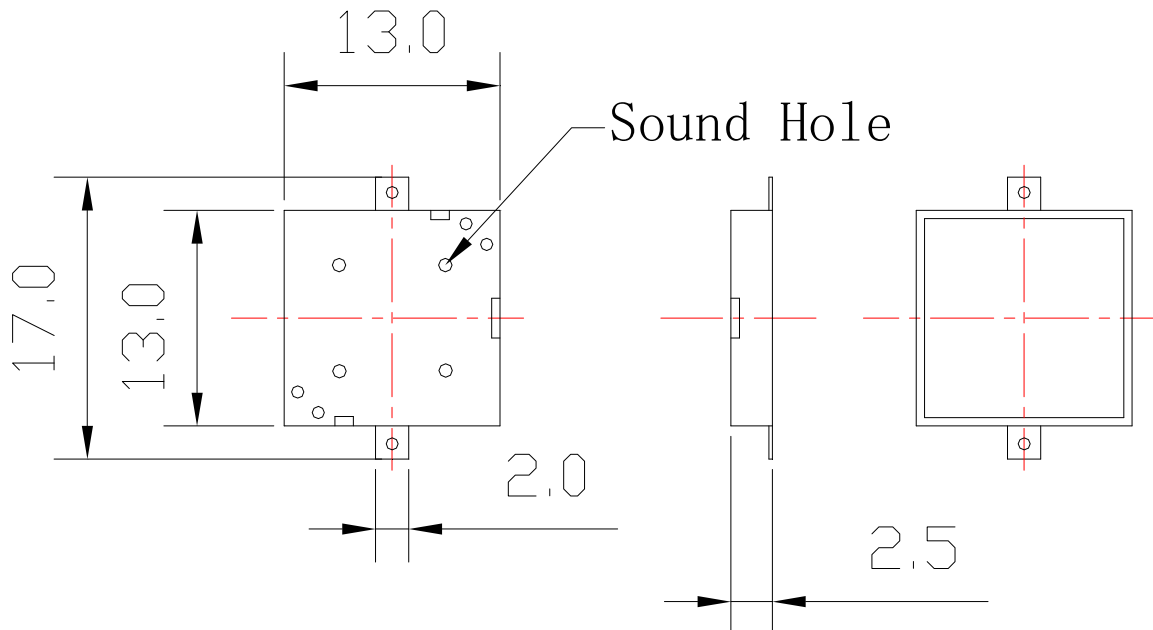

\*Unit: mm; Tolerance: ±0.3mm Except Specified

\*Housing Material: Black LCP

\*Terminal plate: 2 soldering pads, Plating Brass (DSn)

#### 4. Electrical And Acoustical Measuring Condition

##### Recommended Setting

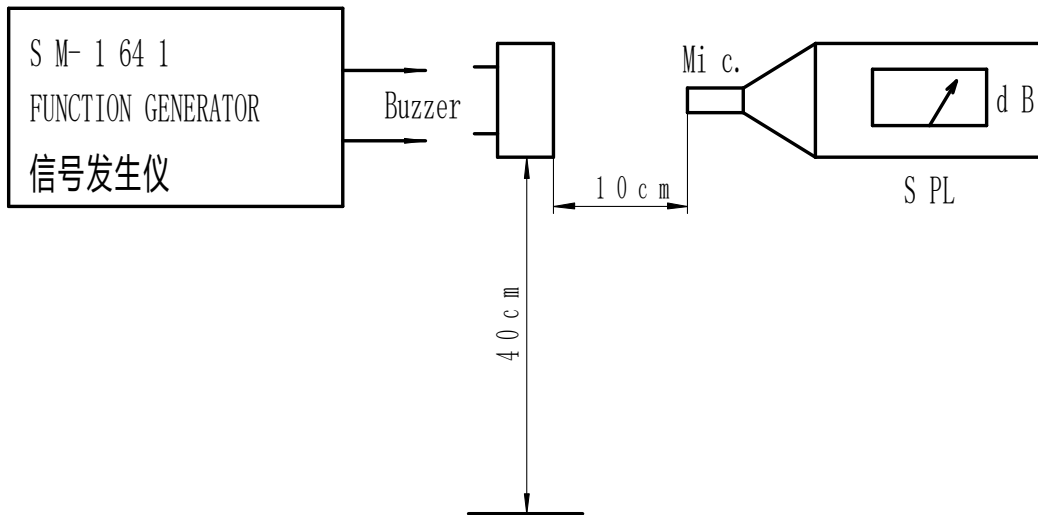

#### 5. Frequency Response

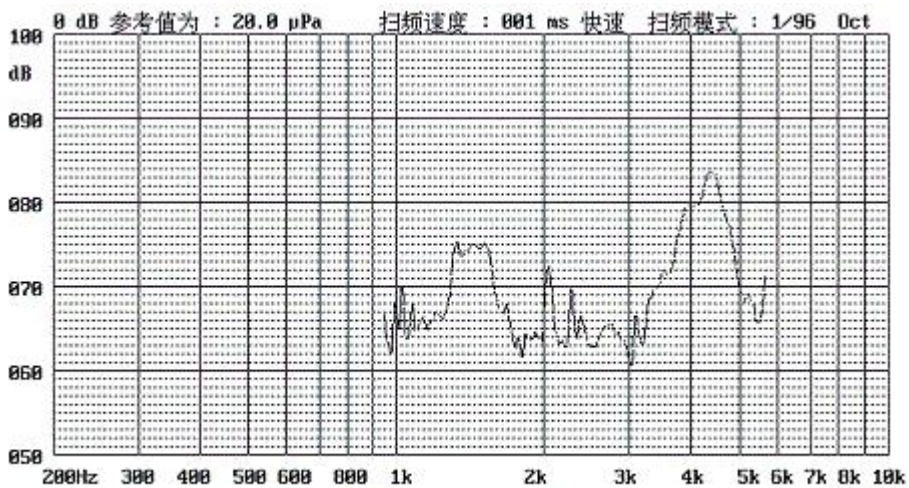

5Vp-p 50% duty Square wave, 10cm

## 6. Surface mounting condition

### 6.1 Reflow soldering

Recommendable reflow soldering condition is as follows.

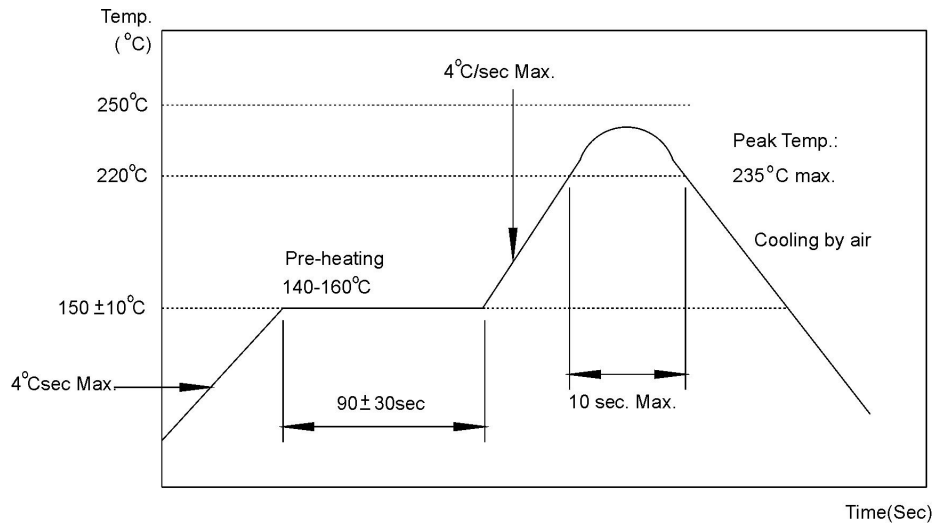

- Note:** (1) In automated mounting of the SMD sound transducers on PCB, any bending, expanding and pulling forces or shocks against the SMD sound transducers shall be kept minimum to prevent them from electrical failures and mechanical damages of the devices.
- (2) In the reflow soldering, too high soldering temperatures and too large temperature Gradient such as rapid heating or cooling may cause electrical failures and mechanical damages of the devices

### 6.2 Soldering pattern

